



型号(1代码·2d)  
ADHB20

■ 请按步骤①~②选择型号和参数后进行订购。



型号区分:  
代码 **7** 天发货



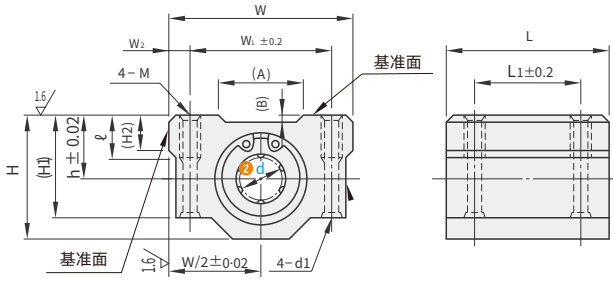

①代码	内置直线轴承	固定座		使用环境温度
		材质	表面处理	
ADHB	ADMU	铝合金	本色阳极氧化	-20~80°C

①代码	②d	公差	L	L1	h	H	(H1)	(H2)	W	W	W2	M	d1	ℓ	(A)	(B)
ADHB	6	0	25	15	9	18	15	6	30	20	5	M4	3.4	8	12	0.4
	8		30	18	11	22	18		34	24					16	
	10		35	21	13	26	21	40	2	6	15.5					
	12		36	26	15	28	24	8	42	30.5	5.75	17.5				
	13	39	30		24.5	44	33		5.5	19	0.85					
	16	44	34	19	38.5	32.5	9	50	36	7	19.8	0.5				
	20	50	40	21	41	35	11	54	40		M6		5.2	21		
	25	67	50	26	51.5	42	12	76	54	11	M8	7	18	36	1	
	30	72	58	30	59.5	49	15	78	58					10		39.9

②d	基本额定负载		静态容许力矩 (N·m)	参考重量(g)
	C(动) N	Co(静)N		
6	206	265	—	34
8	265	380	—	52
10	372	549	—	92
12	412	598	—	102
13	510	784	—	120
16	775	1180	—	220
20	882	1370	—	255
25	980	1570	—	600
30	1570	2740	—	735

国际单位1N=0.102kgf

滚珠  
直线  
导向  
轴  
承  
组  
件  
04



邮箱: Service@srdfaa.com



传真: 0755-8957-5523

**SRD 仕瑞达**